

RATO DS

TECHNISCHE DATEN / TECHNICAL DATA



GÜLTIGKEITSKLAUSEL

Die vorliegende Broschüre ersetzt alle vorherigen Ausgaben, ältere Drucke verlieren ihre Gültigkeit. VULKAN ist berechtigt, aufgrund neuerer Entwicklungen die in dieser Broschüre enthaltenen Daten entsprechend anzupassen und zu verändern. Die neuen Daten gelten nur für nach der Änderung bestellte Kupplungen. Es liegt im Verantwortungsbereich des Anwenders dafür zu sorgen, dass ausschließlich die aktuelle Katalogversion verwendet wird. Der jeweils aktuelle Stand ist auf der Webseite von VULKAN unter www.vulkan.com jederzeit abrufbar.

Die Angaben in dieser Broschüre beziehen sich auf den technischen Standard gültig im Hause VULKAN und stehen unter den in den Erläuterungen definierten Bedingungen. Es liegt allein im Entscheidungs- und Verantwortungsrahmen des Systemverantwortlichen für die Antriebslinie, entsprechende Rückschlüsse auf das Systemverhalten zu ziehen.

VULKAN Drehschwingungsanalysen berücksichtigen in der Regel nur das rein mechanische Schwingungssystem. Als reiner Komponentenhersteller übernimmt VULKAN mit der Analyse des Drehschwingungssystems (stationär, transient) nicht die Systemverantwortung! Die Genauigkeit der Analyse hängt von der Genauigkeit der verwendeten bzw. der VULKAN zur Verfügung gestellten Daten ab.

Änderungen aufgrund des technischen Fortschritts sind vorbehalten. Bei Unklarheiten bzw. Rückfragen kontaktieren Sie bitte VULKAN.

Stand 01/2011

Das Recht auf Vervielfältigung, Nachdruck und Übersetzungen behalten wir uns vor. Maß- und Konstruktionsänderungen vorbehalten.

VALIDITY CLAUSE

The present catalogue shall replace all previous editions, any previous printings shall no longer be valid. Based on new developments, VULKAN reserves the right to amend and change any details contained in this catalogue respectively. The new data shall only apply with respect to couplings that were ordered after said amendment or change. It shall be the responsibility of the user to ensure that only the latest catalogue issue will be used. The respective latest issue can be seen on the website of VULKAN on www.vulkan.com.

The data contained in this catalogue refer to the technical standard as presently used by VULKAN with defined conditions according to the explanations. It shall be the sole responsibility and decision of the system administrator for the drive line to draw conclusions about the system behaviour.

VULKAN torsional vibration analysis usually only consider the pure mechanical mass-elastic system. Being a component manufacturer exclusively, VULKAN assumes no system responsibility with the analysis of the torsional vibration system (stationary, transiently)! The accuracy of the analysis depends on the exactness of the used data and the data VULKAN is provided with, respectively.

Any changes due to the technological progress are reserved. For questions or queries please contact VULKAN.

Status: 01/2011

All duplication, reprinting and translation rights are reserved.

We reserve the right to modify dimensions and constructions without prior notice.

INHALTSVERZEICHNIS

CONTENTS

02

GÜLTIGKEITSKLAUSEL
VALIDITY CLAUSE

03

INHALTSVERZEICHNIS
CONTENTS

04

EIGENSCHAFTEN UND BESCHREIBUNG
CHARACTERISTICS AND DESCRIPTION

06

LISTE DER TECHNISCHEN DATEN
LIST OF TECHNICAL DATA

08

ABMESSUNGEN/MASSENTRÄGHEITSMOMENTE/MASSEN
DIMENSIONS/MASS-MOMENTS OF INERTIA/MASSES

- 08 **RATO DS Baureihe 2200** / Series 2200
- 10 **RATO DS Baureihe 2201** / Series 2201
- 12 **RATO DS Baureihe 2300** / Series 2300
- 14 **RATO DS Baureihe 2301** / Series 2301

EIGENSCHAFTEN UND BESCHREIBUNG

CHARACTERISTICS AND DESCRIPTION

RATO DS Kupplungen / RATO DS Couplings

Drehmoment: 6,30–160,00 kNm / Torque range: 6.30–160.00 kNm



Hochelastische RATO DS Kupplungen

Die hochelastische **RATO DS** Kupplung ist eine VULKAN-Kupplung, die speziell für die Anwendungen in Antriebsanlagen mit der Forderung nach hoher Dreh- und mittlerer Verlagerungsnachgiebigkeit entwickelt wurde.

In Ergänzung zur Allround-Kupplung RATO S wurde die **RATO DS** entwickelt, um eine anwendungsspezifische Kupplungsvariante speziell für starr aufgestellte Schiffshauptantriebe anbieten zu können.

Die zur Verfügung stehenden Drehsteifigkeiten bieten die Möglichkeit einer günstigen Abstimmung mit Hinblick auf stationäres und transientes Drehschwingungsverhalten. In der Tradition der VULKAN-Kupplungen wurde eine spielfreie Elementausführung realisiert. Bei Bedarf lässt sich die DS-Kupplung auch mit einer Durchdrehsicherung ausrüsten.

Die Nachgiebigkeiten der **RATO DS** Kupplung in radialer, axialer und winkliger Richtung sorgen für einen günstigen Ausgleich der Wellenverlagerungen, verursacht durch Fundamentveränderungen, wärme- oder andere betriebsbedingte Verlagerungen.

Bei der Gestaltung der **RATO DS** Kupplung wurde größter Wert auf dynamische Sicherheit gelegt. Dies spiegelt sich einerseits in der Elementgestaltung – mechanische und thermische Sicherheit – und andererseits in der Verwendung von kraftschlüssigen Verschraubungen in der Kupplung wider. Belüftungsquerschnitte in den Metallteilen sorgen für eine gute Wärmeabfuhr aus dem Innern der Kupplung.

Kompakte Abmessungen mit radialer Ausbaumöglichkeit des Elementes sorgen für eine gewichts- und einbaugünstige Konstruktion in der Antriebsanlage.

Die RATO DS Kupplung, Basisbaureihe 2200

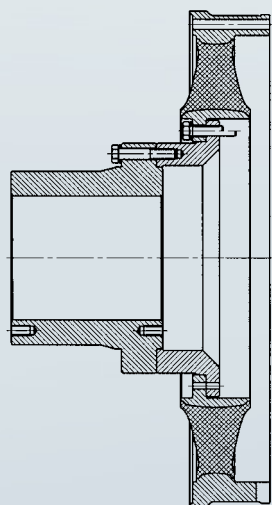

Highly Flexible RATO DS Couplings

The highly flexible **RATO DS** coupling has been specially designed for the use in installations requiring a high level of torsional flexibility and medium level of misalignment capacity.

Supplementing the "all-round" RATO S, the **RATO DS** has been developed to offer an application-oriented coupling design especially for rigidly mounted ship's main propulsions.

The available stiffnesses enable a customized tuning of the system with respect to both the transient and steady-state torsional vibration response. In the tradition of VULKAN couplings, a backlash-free torque transmission is achieved. When required a torque-limiting device can be fitted.

The normal misalignments caused by foundation deflections, heat etc. can be adequately compensated for by the radial, axial and angular flexibility of the **RATO DS**.

Dynamic safety was the prime consideration in the design of the **RATO DS** coupling. This is reflected in the element shape – mechanical and thermal capacity – and by using a friction-loaded bolt arrangement. The ventilation holes located in the coupling's metal parts ensure that any heat generated in the coupling is effectively removed.

The advantages of the compact dimensions together with the possibility of radial removal of the element leads to a weight-efficient coupling assembly in the drive system.

The basic RATO DS, series 2200

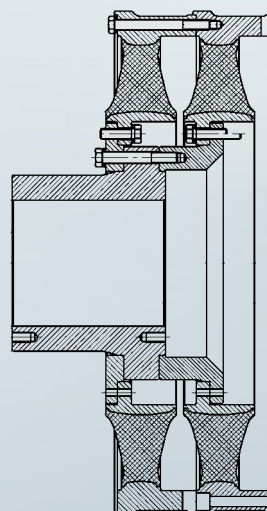

LISTE DER TECHNISCHEN DATEN

LIST OF TECHNICAL DATA

Baugröße	Baugruppe	Nenn-dreh-moment	Max. Dreh-moment ₁	Max. Dreh-moment ₂	Max. Dreh-moment-bereich	Zul. Wech-seldreh-moment	Zul. Verlust-leistung	Zul. Drehzahl	Zul. axialer Wellenver-satz	Zul. radialer Kupplungs-versatz	Axiale Feder-steife	Radiale Feder-steife	Dynamische Drehfeder-steife	Verhält-nismäßige Dämpfung
Size	Dimension Group	Normal Torque	Max. Torque ₁	Max. Torque ₂	Max. Torque Range	Perm. Vibratory Torque	Perm. Power Loss	Perm. Rotational Speed	Perm. Axial Shaft Displacement	Perm. Radial Coupling Displacement	Axial Stiffness	Radial Stiffness	Dynamic Torsional Stiffness	Relative Damping
		T _{KN} kNm	T _{Kmax1} kNm	T _{Kmax2} kNm	ΔT _{max} kNm	T _{KV} kNm	P _{KV50} kW	n _{Kmax} 1/min	ΔK _a mm	ΔK _r mm	C _{ax1.0} kN/mm	C _{rDYN} kN/mm	C _{rDYN} ¹⁾ kNm/rad nominal	ψ ²⁾ nominal
IMPORTANT¹⁾: C_{rDYN warm}, C_{rDYN la}, ψ_{warm} are to be considered!														
A 211Z	A 2110	6,3	7,5	28,0	9,0	2,40	0,36	2100	7,7	1,4	0,5	1,9	32	0,90
A 2111		8,0	8,5	36,0	10,5	2,40			7,7	1,4	0,6	2,4	40	1,13
A 2115		10,0	11,0	45,0	13,5	3,00			5,9	1,1	0,8	3,2	53	1,13
A 2116	A 21D0	10,0	13,5	45,0	16,5	3,00	0,71	2100	3,9	0,7	1,2	4,8	80	1,13
A 21DZ		12,5	15,0	56,5	18,0	4,80			7,7	1,4	1,0	3,8	64	0,90
A 21D1		16,0	17,0	72,0	20,5	4,80			7,7	1,4	1,2	4,8	80	1,13
A 21D5	A 21D0	20,0	22,0	90,0	26,5	6,00	0,71	2100	5,9	1,1	1,6	6,3	105	1,13
A 21D6		20,0	27,5	90,0	33,0	6,00			3,9	0,7	2,4	9,6	160	1,13
A 231Z		8,0	9,5	36,0	11,5	3,00			8,4	1,5	0,5	2,1	40	0,90
A 2311	A 2310	10,0	10,5	45,0	13,0	3,00	0,37	2050	8,4	1,5	0,6	2,6	50	1,13
A 2315		12,5	14,0	56,5	16,5	3,75			6,4	1,1	0,8	3,4	66	1,13
A 2316		12,5	17,0	56,5	20,5	3,75			4,2	0,8	1,3	5,2	100	1,13
A 23DZ	A 23D0	16,0	19,0	72,0	22,5	6,00	0,75	2050	8,4	1,5	1,0	4,2	80	0,90
A 23D1		20,0	21,5	90,0	25,5	6,00			8,4	1,5	1,2	5,2	100	1,13
A 23D5		25,0	28,0	112,5	33,5	7,50			6,4	1,1	1,6	6,8	131	1,13
A 23D6	A 23D0	25,0	34,0	112,5	41,0	7,50	0,75	2050	4,2	0,8	2,6	10,4	200	1,13
A 251Z		10,0	12,0	45,0	14,0	3,75			9,1	1,7	0,5	2,2	50	0,90
A 2511		A 2510	12,5	13,5	56,5	16,0			3,75	9,1	1,7	0,7	2,8	63
A 2515	16,0		18,0	71,0	21,5	4,73	6,9	1,3	0,9	3,7	83	1,13		
A 2516	16,0		22,0	71,0	26,5	4,73	4,6	0,8	1,3	5,6	125	1,13		
A 25DZ	A 25D0	20,0	23,5	90,0	28,5	7,50	0,81	1800	9,1	1,7	1,0	4,4	100	0,90
A 25D1		25,0	27,0	112,5	32,0	7,50			9,1	1,7	1,4	5,6	125	1,13
A 25D5		31,5	35,5	142,0	42,5	9,46			6,9	1,3	1,8	7,4	165	1,13
A 25D6	A 25D0	31,5	44,0	142,0	52,5	9,46	0,81	1800	4,6	0,8	2,6	11,2	250	1,13
A 271Z		12,5	15,0	56,5	18,0	4,73			9,8	1,8	0,6	2,4	63	0,90
A 2711		A 2710	16,0	17,0	71,0	20,5			4,73	9,8	1,8	0,7	3,0	79
A 2715	20,0		22,0	90,0	26,5	6,00	7,5	1,4	0,9	4,0	105	1,13		
A 2716	20,0		27,5	90,0	33,0	6,00	4,9	0,9	1,4	6,0	158	1,13		
A 27DZ	A 27D0	25,0	30,0	112,5	36,0	9,46	0,87	1700	9,8	1,8	1,2	4,8	126	0,90
A 27D1		31,5	34,5	142,0	41,0	9,46			9,8	1,8	1,4	6,0	158	1,13
A 27D5		40,0	44,5	180,0	53,5	12,00			7,5	1,4	1,8	7,9	210	1,13
A 27D6	A 27D0	40,0	54,5	180,0	65,5	12,00	0,87	1700	4,9	0,9	2,8	12,0	316	1,13
A 291Z		16,0	19,0	71,0	22,5	6,00			10,7	2,0	0,6	2,5	80	0,90
A 2911		A 2910	20,0	21,5	90,0	25,5			6,00	10,7	2,0	0,8	3,2	100
A 2915	25,0		28,0	112,5	33,5	7,50	8,2	1,5	1,1	4,2	132	1,13		
A 2916	25,0		34,0	112,5	41,0	7,50	5,4	1,0	1,5	6,5	200	1,13		
A 29DZ	A 29D0	31,5	37,5	142,0	45,5	12,00	0,94	1600	10,7	2,0	1,2	5,0	160	0,90
A 29D1		40,0	43,0	180,0	51,5	12,00			10,7	2,0	1,6	6,4	200	1,13
A 29D5		50,0	55,5	225,0	66,5	15,00			8,2	1,5	2,1	8,4	263	1,13
A 29D6	A 29D0	50,0	68,5	225,0	82,0	15,00	0,94	1600	5,4	1,0	3,0	13,0	400	1,13

Siehe Erläuterung der Technischen Daten

- VULKAN empfiehlt die zusätzliche Berücksichtigung von C_{rDYN warm} (0,7), C_{rDYN la} (1,35) und ψ_{warm} (0,7) für die Berechnung der Drehschwingungen in der Anlage.
Durch die Eigenschaft des Werkstoffs Gummi sind Toleranzen der aufgeführten Daten für C_{rDYN} von ± 15% möglich.
- Bedingt durch die physikalischen Eigenschaften der elastischen Elemente sind Toleranzen der aufgeführten Daten für ψ, von 10% bis -20% für die Z Elemente bzw., von 0% bis -30% für die 1, 5, 6 Elemente möglich.

See Explanation of Technical Data

- VULKAN recommend that the values C_{rDYN warm} (0.7), C_{rDYN la} (1.35) and ψ_{warm} (0.7) be additionally used when the installations of torsional vibrations are calculated.
The properties of the rubber material mean that tolerances of ± 15% with respect to the data given for C_{rDYN} are possible.
- Because of the physical properties of the elastic elements, tolerances of 10% to -20% for the Z elements and 0% to -30% for the 1, 5, 6 elements with respect to the data given for ψ are possible.

Baugröße	Baugruppe	Nenn-drehmoment	Max. Drehmoment ₁	Max. Drehmoment ₂	Max. Drehmomentbereich	Zul. Wech-seldrehmoment	Zul. Verlustleistung	Zul. Drehzahl	Zul. axialer Wellenversatz	Zul. radialer Kupplungsversatz	Axiale Federsteife	Radiale Federsteife	Dynamische Drehfedersteife	Verhältnismäßige Dämpfung
Size	Dimension Group	Normal Torque	Max. Torque ₁	Max. Torque ₂	Max. Torque Range	Perm. Vibratory Torque	Perm. Power Loss	Perm. Rotational Speed	Perm. Axial Shaft Displacement	Perm. Radial Coupling Displacement	Axial Stiffness	Radial Stiffness	Dynamic Torsional Stiffness	Relative Damping
		T _{KN} kNm	T _{Kmax1} kNm	T _{Kmax2} kNm	ΔT _{max} kNm	T _{KW} kNm	P _{KV50} kW	n _{Kmax} 1/min	ΔK _a mm	ΔK _r mm	C _{ax1.0} kN/mm	C _{r1dyn} kN/mm	C _{Tdyn} ¹⁾ kNm/rad nominal	ψ ²⁾ nominal
IMPORTANT¹⁾: C_{Tdyn warm}, C_{Tdyn la}, ψ_{warm} are to be considered!														
A 311Z	A 3110	20,0	23,5	90,0	28,5	7,50	0,50	1410	11,2	2,0	0,7	2,8	100	0,90
A 3111		25,0	27,0	112,5	32,0	7,50			11,2	2,0	0,9	3,6	125	1,13
A 3115		31,5	35,0	142,0	42,0	9,45			8,5	1,5	1,2	4,8	166	1,13
A 3116		31,5	43,0	142,0	51,5	9,45			5,6	1,0	1,7	7,1	250	1,13
A 31DZ	A 31D0	40,0	47,0	180,0	56,5	15,00	1,00	1410	11,2	2,0	1,4	5,6	200	0,90
A 31D1		50,0	53,5	225,0	64,5	15,00			11,2	2,0	1,8	7,2	250	1,13
A 31D5		63,0	70,0	283,5	84,0	18,90			8,5	1,5	2,4	9,5	331	1,13
A 31D6		63,0	86,0	283,5	103,5	18,90			5,6	1,0	3,4	14,2	500	1,13
A 331Z	A 3310	25,0	29,5	112,5	35,5	9,45	0,57	1350	12,5	2,3	0,7	3,0	126	0,90
A 3311		31,5	34,0	142,0	40,5	9,45			12,5	2,3	0,9	3,8	158	1,13
A 3315		40,0	44,5	180,0	53,5	12,00			9,5	1,8	1,2	5,0	210	1,13
A 3316		40,0	54,5	180,0	65,5	12,00			6,3	1,1	1,8	7,5	315	1,13
A 33DZ	A 33D0	50,0	59,5	225,0	71,5	18,90	1,13	1350	12,5	2,3	1,4	6,0	252	0,90
A 33D1		63,0	67,5	283,5	81,0	18,90			12,5	2,3	1,8	7,6	315	1,13
A 33D5		80,0	89,0	360,0	107,0	24,00			9,5	1,8	2,4	10,0	420	1,13
A 33D6		80,0	109,5	360,0	131,5	24,00			6,3	1,1	3,6	15,0	630	1,13
A 341Z	A 3410	31,5	37,5	142,0	45,5	12,00	0,62	1250	13,5	2,5	0,8	3,2	160	0,90
A 3411		40,0	43,0	180,0	51,5	12,00			13,5	2,5	1,0	4,0	200	1,13
A 3415		50,0	55,5	225,0	66,5	15,00			10,3	2,0	1,3	5,3	263	1,13
A 3416		50,0	68,5	225,0	82,0	15,00			6,8	1,3	2,0	8,0	400	1,13
A 34DZ	A 34D0	63,0	75,5	283,5	90,5	24,00	1,23	1250	13,5	2,5	1,6	6,4	320	0,90
A 34D1		80,0	86,0	360,0	103,0	24,00			13,5	2,5	2,0	8,0	400	1,13
A 34D5		100,0	111,0	450,0	133,5	30,00			10,3	2,0	2,6	10,5	525	1,13
A 34D6		100,0	137,0	450,0	164,0	30,00			6,8	1,3	4,0	16,0	800	1,13
A 391Z	A 3910	50,0	55,5	225,0	66,5	18,75	0,66	1040	15,5	3,0	1,0	4,5	250	0,90
A 3911		63,0	66,0	281,5	80,5	18,75			14,0	2,7	1,5	6,0	313	1,13
A 3915		80,0	85,0	360,0	103,0	24,00			11,0	2,5	1,9	7,9	420	1,13
A 3916		80,0	105,0	360,0	125,0	24,00			7,5	1,7	2,6	11,5	640	1,13
A 39DZ	A 39D0	100,0	111,0	450,0	133,0	37,50	1,32	1040	15,5	3,0	2,0	9,0	500	0,90
A 39D1		125,0	132,0	562,5	161,0	37,50			14,0	2,7	3,0	12,0	625	1,13
A 39D5		160,0	170,0	720,0	206,0	48,00			11,0	2,5	3,8	15,8	840	1,13
A 39D6		160,0	210,0	720,0	250,0	48,00			7,5	1,7	5,2	23,0	1280	1,13

Siehe Erläuterung der Technischen Daten

- 1) VULKAN empfiehlt die zusätzliche Berücksichtigung von C_{Tdyn warm} (0,7), C_{Tdyn la} (1,35) und ψ_{warm} (0,7) für die Berechnung der Drehschwingungen in der Anlage.
Durch die Eigenschaft des Werkstoffs Gummi sind Toleranzen der aufgeführten Daten für C_{Tdyn} von ± 15 % möglich.
- 2) Bedingt durch die physikalischen Eigenschaften der elastischen Elemente sind Toleranzen der aufgeführten Daten für ψ, von 10% bis -20% für die Z Elemente bzw., von 0% bis -30% für die 1, 5, 6 Elemente möglich.

See Explanation of Technical Data

- 1) VULKAN recommend that the values C_{Tdyn warm} (0.7), C_{Tdyn la} (1.35) and ψ_{warm} (0.7) be additionally used when the installations of torsional vibrations are calculated.
The properties of the rubber material mean that tolerances of ± 15% with respect to the data given for C_{Tdyn} are possible.
- 2) Because of the physical properties of the elastic elements, tolerances of 10% to -20% for the Z elements and 0% to -30% for the 1, 5, 6 elements with respect to the data given for ψ are possible.

ABMESSUNGEN/MASSESTRÄGHEITSMOMENTE/MASSEN

DIMENSIONS/MASS-MOMENTS OF INERTIA/MASSES

RATO DS Baureihe / Series 2200

Baugruppe	Abmessungen																Massenträgheitsmoment		Masse		Schwerpunktsabstand		
	Dimension Group	Dimensions																Mass moment of inertia		Mass		Distance to center of gravity	
T_{KN} [kNm]		D_1	D_2	D_3	D_4 max	D_5 vorgeb. pilot bored	D_6 L_{H_1}	D_7 Bohrung hole	L_1	L_2	L_3	L_4	L_5	L_6	F_1	T_1	T_2	J_1	J_2	m_1	m_2	s_1	s_2
A2110	6,3-10,0	645	635	223,0	160,0	80,0	608,0	13,5	325,00	185,0	140,0	100,0	12	-	1,6	16	-	4,5	1,5	50,00	98,0	57,0	153,0
A21D0	12,5-20,0	645	635	223,0	160,0	80,0	608,0	13,5	325,00	185,0	140,0	205,0	12	82,0	1,6	32	16	8,8	2,3	99,00	123,0	109,0	150,0
A2310	8,0-12,5	690	680	238,0	170,0	110,0	650,0	15,5	350,00	195,0	155,0	110,0	12	-	1,6	16	-	6,7	2,1	67,00	112,0	62,0	169,0
A23D0	16,0-25,0	690	680	238,0	170,0	110,0	650,0	15,5	350,00	195,0	155,0	255,0	12	90,0	1,6	32	16	13,3	3,2	131,00	146,0	120,0	163,0
A2510	10,0-16,0	740	730	258,0	185,0	110,0	700,0	15,5	385,00	225,0	160,0	115,0	12	-	2,0	16	-	8,9	3,2	75,00	148,0	65,0	184,0
A25D0	20,0-31,5	740	730	258,0	185,0	110,0	700,0	15,5	385,00	225,0	160,0	235,0	12	95,0	2,0	32	16	17,5	4,8	149,00	187,0	125,0	181,0
A2710	12,5-20,0	800	790	278,0	200,0	100,0	755,0	17,5	410,00	235,0	175,0	125,0	12	-	2,0	16	-	13,5	4,5	98,00	187,0	70,0	192,0
A27D0	25,0-40,0	800	790	278,0	200,0	100,0	755,0	17,5	410,00	235,0	175,0	255,0	12	103,0	2,0	32	16	26,6	6,9	194,00	238,0	136,0	189,0
A2910	16,0-25,0	870	860	306,0	220,0	110,0	820,0	20,0	440,00	250,0	190,0	135,0	12	-	2,0	16	-	21,8	6,8	128,00	238,0	75,0	204,0
A29D0	31,5-50,0	870	860	306,0	220,0	110,0	820,0	20,0	440,00	250,0	190,0	275,0	12	111,0	2,0	32	16	41,2	10,3	254,00	299,0	146,0	200,0
A3110	20,0-31,5	935	920	325,0	235,0	115,0	880,0	20,0	475,00	285,0	190,0	140,0	16	-	3,0	16	-	28,1	10,0	151,00	306,0	78,0	225,0
A31D0	40,0-63,0	935	920	325,0	235,0	115,0	880,0	20,0	475,00	285,0	190,0	285,0	16	116,0	3,0	32	16	55,7	15,0	299,00	381,0	152,0	223,0
A3310	25,0-40,0	1010	995	357,0	255,0	150,0	950,0	22,0	495,00	300,0	195,0	150,0	16	-	3,0	16	-	39,9	14,2	182,00	363,0	84,0	236,0
A33D0	50,0-80,0	1010	995	357,0	255,0	150,0	950,0	22,0	495,00	300,0	195,0	305,0	16	124,0	3,0	32	16	78,9	21,6	361,00	459,0	163,0	231,0
A3410	31,5-50,0	1085	1070	385,0	275,0	160,0	1025,0	24,0	530,00	310,0	220,0	160,0	16	-	3,0	16	-	55,7	20,5	220,00	446,0	89,0	250,0
A34D0	63,0-100,0	1085	1070	385,0	275,0	160,0	1025,0	24,0	530,00	310,0	220,0	325,0	16	132,0	3,0	32	16	110,3	31,1	435,00	563,0	173,0	246,0
A3910	50,0-80,0	1255	1240	448,0	320,0	200,0	1190,0	26,0	635,00	385,0	250,0	182,0	21	-	4,0	16	-	112,0	44,6	327,00	717,0	102,0	307,0
A30D0	100,0-160,0	1255	1240	448,0	320,0	200,0	1190,0	26,0	635,00	385,0	250,0	369,0	21	152,0	4,0	32	16	221,0	67,1	647,00	900,0	197,0	304,0

Maße in mm

Alle Massen und Massenträgheitsmomente beziehen sich auf vorgebohrte Naben.

Dimensions in mm

All masses and mass moments of inertia refer to pilot bored hubs.

RATO DS Baureihe / Series 2200

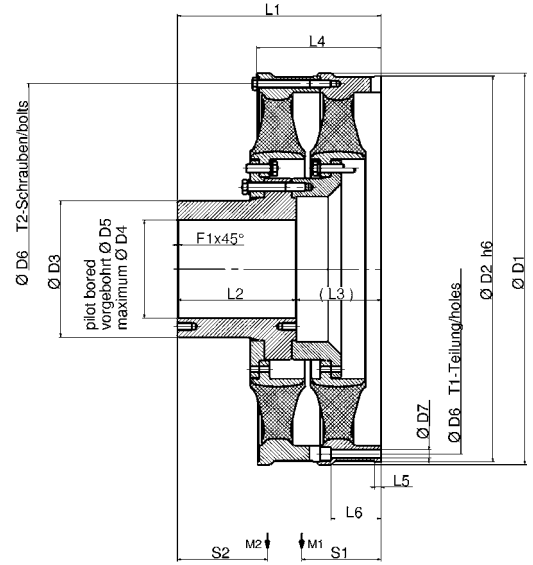
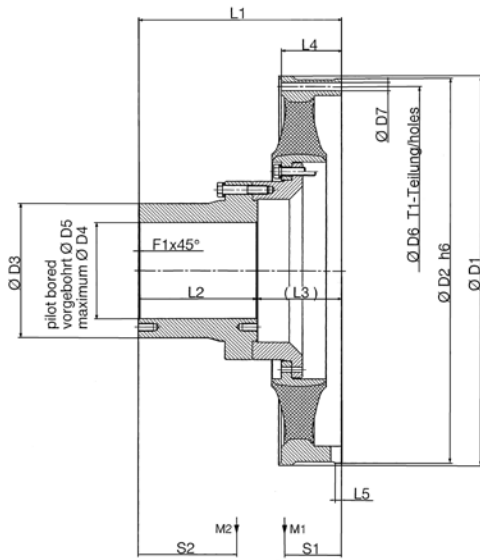

ABMESSUNGEN/MASSENTRÄGHEITSMOMENTE/MASSEN

DIMENSIONS/MASS-MOMENTS OF INERTIA/MASSES

RATO DS Baureihe / Series 2201

Baugruppe	Abmessungen																	Massenträgheitsmoment		Masse		Schwerpunktsabstand	
	Dimension Group	Dimensions																	Mass moment of inertia		Mass		Distance to center of gravity
T_{NN} [kNm]		D_1	D_2	D_3	D_4	D_5	D_6	D_7	L_1	L_2	L_3	L_4	L_5	L_6	F_1	T_1	T_2	J_1	J_2	m_1	m_2	s_1	s_2
																		[kgm ²]		kg		[mm]	
A2110	6,3-10,0	645	635	223,0	160,0	80,0	608,0	13,5	325,00	185,0	140,0	113,0	12	-	1,6	16	-	5,7	2,0	66,00	110,0	68,0	160,0
A21D0	12,5-20,0	645	635	223,0	160,0	80,0	608,0	13,5	325,00	185,0	140,0	205,0	12	82,0	1,6	32	16	9,9	2,7	113,00	133,0	122,0	146,0
A2310	8,0-12,5	690	680	238,0	170,0	110,0	650,0	15,5	350,00	195,0	155,0	124,0	12	-	1,6	16	-	8,8	2,6	90,00	123,0	74,0	162,0
A23D0	16,0-25,0	690	680	238,0	170,0	110,0	650,0	15,5	350,00	195,0	155,0	225,0	12	90,0	1,6	32	16	14,9	3,7	149,50	159,0	134,0	159,0
A2510	10,0-16,0	740	730	258,0	185,0	110,0	700,0	15,5	385,00	225,0	160,0	130,0	12	-	2,0	16	-	11,4	3,8	99,00	171,0	79,0	189,0
A25D0	20,0-31,5	740	730	258,0	185,0	110,0	700,0	15,5	385,00	225,0	160,0	235,0	12	95,0	2,0	32	16	19,9	5,4	172,00	207,0	141,0	177,0
A2710	12,5-20,0	800	790	278,0	200,0	100,0	755,0	17,5	410,00	235,0	175,0	141,0	12	-	2,0	16	-	17,0	6,1	126,00	216,0	84,0	201,0
A27D0	25,0-40,0	800	790	278,0	200,0	100,0	755,0	17,5	410,00	235,0	175,0	255,0	12	103,0	2,0	32	16	29,7	8,1	219,00	261,0	151,0	183,0
A2910	16,0-25,0	870	860	306,0	220,0	110,0	820,0	20,0	440,00	250,0	190,0	152,0	12	-	2,0	16	-	26,6	8,6	167,00	268,0	90,0	212,0
A29D0	31,5-50,0	870	860	306,0	220,0	110,0	820,0	20,0	440,00	250,0	190,0	275,0	12	111,0	2,0	32	16	46,2	11,8	288,00	325,0	164,0	194,0
A3110	20,0-31,5	935	920	325,0	235,0	115,0	880,0	20,0	475,00	285,0	190,0	159,0	16	-	3,0	16	-	36,4	12,5	201,00	341,0	96,0	233,0
A31D0	40,0-63,0	935	920	325,0	235,0	115,0	880,0	20,0	475,00	285,0	190,0	285,0	16	116,0	3,0	32	16	63,2	17,2	344,00	413,0	171,0	218,0
A3310	25,0-40,0	1010	995	357,0	255,0	150,0	950,0	22,0	495,00	300,0	195,0	171,0	16	-	3,0	16	-	52,4	19,0	246,00	428,0	103,0	242,0
A33D0	50,0-80,0	1010	995	357,0	255,0	150,0	950,0	22,0	495,00	300,0	195,0	305,0	16	124,0	3,0	32	16	89,9	25,1	418,00	502,0	185,0	224,0
A3410	31,5-50,0	1085	1070	385,0	275,0	160,0	1025,0	24,0	530,00	310,0	220,0	183,0	16	-	3,0	16	-	73,7	25,0	300,00	516,0	111,0	256,0
A34D0	63,0-100,0	1085	1070	385,0	275,0	160,0	1025,0	24,0	530,00	310,0	220,0	325,0	16	132,0	3,0	32	16	126,0	35,8	55,00	613,0	197,0	239,0
A3910	50,0-80,0	1255	1240	448,0	320,0	200,0	1190,0	26,0	635,00	385,0	250,0	182,0	20	-	4,0	16	-	139,0	55,5	421,00	837,0	130,0	312,0
A30D0	100,0-160,0	1255	1240	448,0	320,0	200,0	1190,0	26,0	635,00	385,0	250,0	369,0	20	152,0	4,0	32	16	255,0	77,7	759,00	980,0	226,0	296,0

Maße in mm

Alle Massen und Massenträgheitsmomente beziehen sich auf vorgebohrte Naben.

Dimensions in mm

All masses and mass moments of inertia refer to pilot bored hubs.

RATO DS Baureihe / Series 2201

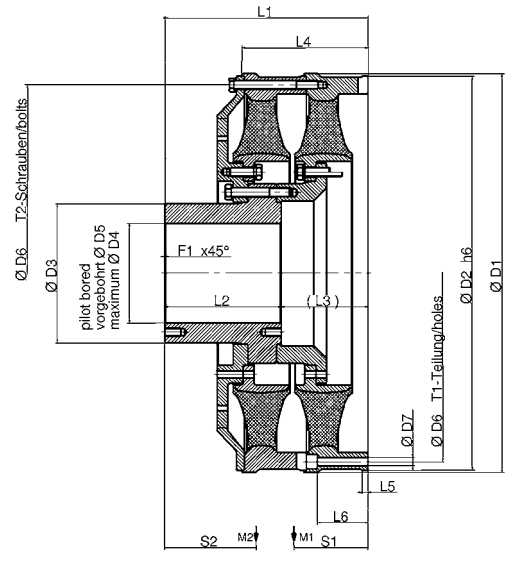
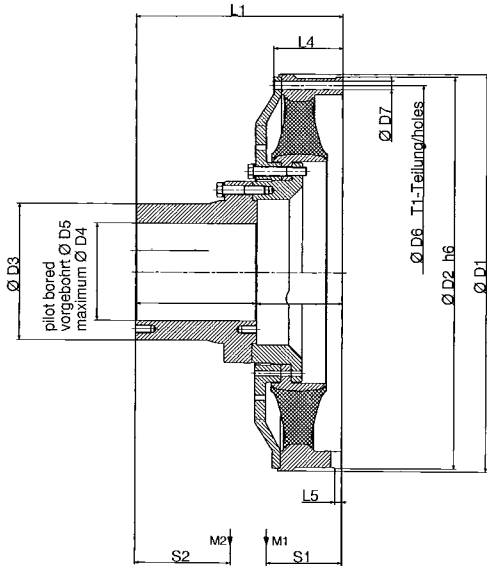

ABMESSUNGEN/MASSENTRÄGHEITSMOMENTE/MASSEN

DIMENSIONS/MASS-MOMENTS OF INERTIA/MASSES

RATO DS Baureihe / Series 2300

Baugruppe	Abmessung																								
	Dimension Group	Dimensions																							
T _{KW} [kNm]		D ₁	D ₂	D ₃	D ₄	D ₅	D ₆	D ₇	D ₈	D ₉	D ₁₀	D ₁₁	L ₁	L ₂	L ₃	L ₄	L ₅	L ₆	L ₈	L ₉	F ₁	T ₁	T ₂	T ₃	Gew.
A2110	6,3-10,0	645	635	296,0	230,0	264,0	608,0	13,5	-	-	-	-	148,00	8,0	33,0	100,0	12	28,0	-	-	1,6	16	-	20	M16
A21D0	12,5-20,0	645	635	223,0	230,0	230,0	608,0	13,5	608	296	264,0	17,5	215,00	44,0	140,0	205,0	12	82,0	8,0	8,0	-	32	16	20	-
A2310	8,0-12,5	690	680	307,0	242,0	275,0	650,0	15,5	-	-	-	-	164,00	9,0	37,0	110,0	12	26,0	-	-	1,6	16	-	24	M16
A23D0	16,0-25,0	690	680	238,0	242,0	242,0	650,0	15,5	650	307	275,0	17,5	237,00	46,0	155,0	225,0	12	90,0	9,0	9,0	-	32	16	24	-
A2510	10,0-16,0	740	730	342,0	270,0	310,0	700,0	15,5	-	-	-	-	169,00	9,0	36,0	115,0	12	31,0	-	-	2,0	16	-	24	M16
A25D0	20,0-31,5	740	730	258,0	270,0	270,0	700,0	15,5	700	342	310,0	17,5	248,00	52,0	160,0	235,0	12	95,0	9,0	9,0	-	32	16	24	-
A2710	12,5-20,0	800	790	360,0	284,0	324,0	755,0	17,5	-	-	-	-	185,00	10,0	37,0	125,0	12	32,0	-	-	2,0	16	-	24	M18
A27D0	25,0-40,0	800	790	278,0	284,0	284,0	755,0	17,5	755	360	324,0	20,0	272,50	57,5	175,0	255,0	12	103,0	10,0	10,0	-	32	16	24	-
A2910	16,0-25,0	870	860	392,0	312,0	352,0	820,0	20,0	-	-	-	-	200,00	10,0	41,0	135,0	12	35,0	-	-	2,0	16	-	24	M20
A29D1	31,5-50,0	870	860	306,0	312,0	312,0	820,0	20,0	820	392	352,0	22,0	294,00	64,0	190,0	275,0	12	111,0	10,0	10,0	-	32	16	24	-
A3110	20,0-31,5	935	920	435,0	340,0	395,0	880,0	20,0	-	-	-	-	200,00	10,0	37,0	140,0	16	35,0	-	-	2,0	16	-	24	M20
A31D0	40,0-63,0	935	920	325,0	340,0	340,0	880,0	20,0	880	435	395,0	22,0	303,00	73,0	190,0	285,0	16	116,0	10,0	10,0	-	32	16	24	-
A3310	25,0-40,0	1010	995	457,0	365,0	413,0	950,0	22,0	-	-	-	-	205,00	10,0	30,0	150,0	16	30,0	-	-	2,0	16	-	24	M22
A33D0	50,0-80,0	1010	995	357,0	365,0	365,0	950,0	22,0	950	457	413,0	24,0	235,00	85,0	195,0	305,0	16	124,0	10,0	12,0	-	32	16	24	-
A3410	31,5-50,0	1085	1070	495,0	395,0	445,0	1025,0	24,0	-	-	-	-	231,00	11,0	44,0	160,0	16	44,0	-	-	2,0	16	-	24	M24
A34D0	63,0-100,0	1085	1070	385,0	395,0	395,0	1025,0	24,0	1025	495	445,0	26,0	347,00	81,0	220,0	325,0	16	132,0	11,0	11,0	-	32	16	24	-
A3910	50,0-80,0	1255	1240	580,0	465,0	525,0	1190,0	26,0	-	-	-	-	262,00	12,0	48,0	182,0	20	45,0	-	-	2,0	16	-	24	M27
A39D0	100,0-160,0	1255	1240	448,0	465,0	465,0	1190,0	26,0	1190	580	525,0	30,0	396,00	92,0	250,0	369,0	20	152,0	12,0	12,0	-	32	16	24	-

Maße in mm

Alle Massen und Massenträgheitsmomente beziehen sich auf vorgebohrte Naben.

Dimensions in mm

All masses and mass moments of inertia refer to pilot bored hubs.

RATO DS Baureihe / Series 2300

Massenträgheitsmoment		Masse		Schwerpunktsabstand	
Mass moment of inertia		Mass		Distance to center of gravity	
J_1	J_2	m_1	m_2	s_1	s_2
[kgm ²]		[kg]		[mm]	
4,6	1,1	52,00	37,0	56,0	58,0
9,3	1,9	104,00	65,0	106,0	87,0
7,1	1,4	70,00	47,0	61,0	66,0
14,1	2,6	139,00	81,0	116,0	95,0
9,2	2,0	78,00	55,0	64,0	67,0
18,4	3,8	156,00	98,0	122,0	99,0
14,1	3,1	102,00	72,0	70,0	73,0
28,1	5,7	204,00	125,0	132,0	108,0
21,8	4,4	134,00	86,0	74,0	78,0
43,1	8,1	268,00	153,0	142,0	116,0
29,3	6,2	157,00	103,0	78,0	75,0
58,7	11,6	314,00	184,0	148,0	120,0
41,8	9,0	191,00	127,0	83,0	19,0
83,5	16,6	381,00	227,0	159,0	131,0
58,7	12,4	232,00	156,0	89,0	88,0
117,4	22,7	464,00	273,0	169,0	137,0
107,0	26,5	315,00	242,0	102,0	102,0
214,0	48,0	630,00	417,0	193,0	161,0

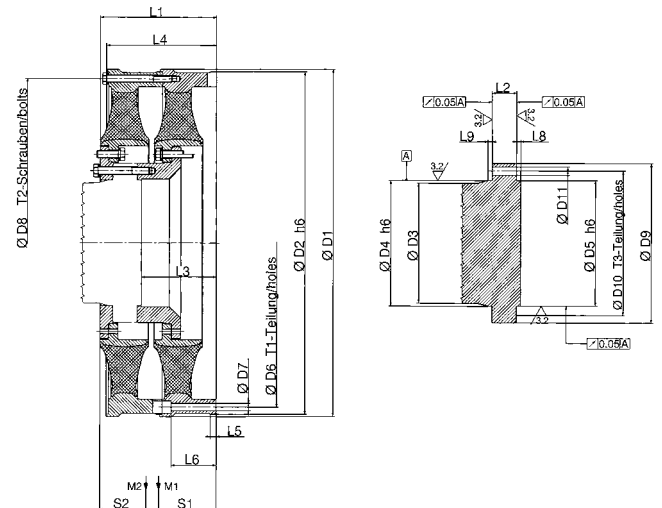
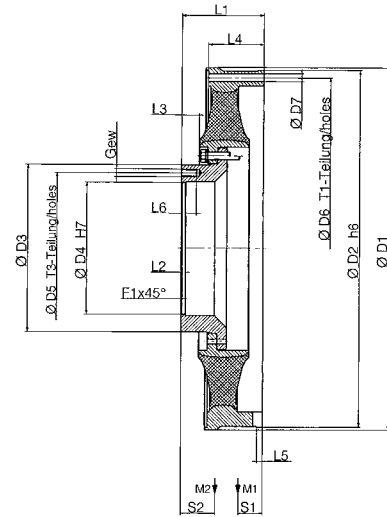

ABMESSUNGEN/MASSENTRÄGHEITSMOMENTE/MASSEN

DIMENSIONS/MASS-MOMENTS OF INERTIA/MASSES

RATO DS Baureihe / Series 2301

Baugruppe	Abmessungen																								
	TKN [kNm]	Dimensions																						Gew.	
D ₁		D ₂	D ₃	D ₄	D ₅	D ₆	D ₇	D ₈	D ₉	D ₁₀	D ₁₁	L ₁	L ₂	L ₃	L ₄	L ₅	L ₆	L ₈	L ₉	F ₁	T ₁	T ₂	T ₃		
A 2110	6,3 - 10,0	645	635	296,0	230,0	264,0	608,0	13,5	-	-	-	-	148,00	8,0	7,5	113,0	12	28,0	-	-	2,0	16	-	20	M16
A 21D0	12,5 - 20,0	645	635	223,0	230,0	230,0	608,0	13,5	608	296	264,0	17,5	242,00	44,0	140,0	205,0	12	82,0	8,0	8	-	32	16	20	-
A 2310	8,0 - 12,5	690	680	307,0	242,0	275,0	650,0	15,5	-	-	-	-	164,00	9,0	5,5	124,0	12	26,0	-	-	2,0	16	-	24	M16
A 23D0	16,0 - 25,0	690	680	238,0	242,0	242,0	650,0	15,5	650	307	275,0	17,5	265,00	46,0	155,0	225,0	12	90,0	9,0	9	-	32	16	24	-
A 2510	10,0 - 16,0	740	730	342,0	270,0	310,0	700,0	15,5	-	-	-	-	169,00	9,0	8,5	130,0	12	31,0	-	-	2,0	16	-	24	M16
A 25D0	20,0 - 31,5	740	730	258,0	270,0	270,0	700,0	15,5	700	342	310,0	17,5	278,00	52,0	160,0	235,0	12	95,0	9,0	9	-	32	16	24	-
A 2710	12,5 - 20,0	800	790	360,0	284,0	324,0	755,0	17,5	-	-	-	-	185,00	10,0	10,5	141,0	12	32,0	-	-	2,0	16	-	24	M18
A 27D0	25,0 - 40,0	800	790	278,0	284,0	284,0	755,0	17,5	755	360	324,0	20,0	304,50	57,5	175,0	255,0	12	103,0	10,0	10	-	32	16	24	-
A 2910	16,0 - 25,0	870	860	392,0	312,0	352,0	820,0	20,0	-	-	-	-	200,00	10,0	9,0	152,0	12	35,0	-	-	2,0	16	-	24	M20
A 29D1	31,5 - 50,0	870	860	306,0	312,0	312,0	820,0	20,0	820	392	352,0	22,0	327,00	64,0	190,0	275,0	12	111,0	10,0	10	-	32	16	24	-
A 3110	20,0 - 31,5	935	920	435,0	340,0	395,0	880,0	20,0	-	-	-	-	200,00	10,0	15,0	159,0	16	35,0	-	-	2,0	16	-	24	M20
A 31D0	40,0 - 63,0	935	920	325,0	340,0	340,0	880,0	20,0	880	435	395,0	22,0	338,00	73,0	190,0	285,0	16	116,0	10,0	10	-	32	16	24	-
A 3310	25,0 - 40,0	1010	995	457,0	365,0	413,0	950,0	22,0	-	-	-	-	205,00	10,0	26,5	171,0	16	30,0	-	-	2,0	16	-	24	M22
A 33D0	50,0 - 80,0	1010	995	357,0	365,0	365,0	950,0	22,0	950	457	413,0	24,0	363,00	85,0	195,0	305,0	16	124,0	10,0	12	-	32	16	24	-
A 3410	31,5 - 50,0	1085	1070	495,0	395,0	445,0	1025,0	24,0	-	-	-	-	231,00	11,0	15,5	183,0	16	44,0	-	-	2,0	16	-	24	M24
A 34D0	63,0 - 100,0	1085	1070	385,0	395,0	395,0	1025,0	24,0	1025	495	445,0	26,0	387,00	81,0	220,0	325,0	16	132,0	11,0	11	-	32	16	24	-
A 3910	50,0 - 80,0	1255	1240	580,0	465,0	525,0	1190,0	26,0	-	-	-	-	262,00	12,0	23,0	211,0	20	45,0	-	-	2,0	16	-	24	M27
A 39D0	100,0 - 160,0	1255	1240	448,0	465,0	465,0	1190,0	26,0	1190	580	525,0	30,0	444,00	92,0	250,0	369,0	20	152,0	12,0	12	-	32	16	24	-

Maße in mm

Alle Massen und Massenträgheitsmomente beziehen sich auf vorgebohrte Naben.

Dimensions in mm

All masses and mass moments of inertia refer to pilot bored hubs.

RATO DS Baureihe / Series 2301

Massenträgheitsmoment		Masse		Schwerpunktsabstand	
Mass moment of inertia		Mass		Distance to center of gravity	
J_1	J_2	m_1	m_2	s_1	s_2
[kgm ²]		[kg]		[mm]	
5,7	1,5	66,00	50,0	68,0	49,0
10,4	2,2	118,00	74,0	119,0	108,0
8,8	1,9	90,00	62,0	74,0	58,0
15,8	2,9	159,00	91,0	131,0	117,0
11,4	2,7	99,00	73,0	79,0	57,0
20,6	4,3	177,00	110,0	137,0	127,0
17,0	4,5	126,00	100,0	84,0	60,0
31,0	6,5	228,00	145,0	146,0	130,0
26,6	6,2	167,00	118,0	90,0	65,0
47,9	9,4	301,00	176,0	158,0	139,0
36,4	8,7	201,00	140,0	96,0	61,0
65,8	13,5	358,00	211,0	167,0	148,0
52,4	13,0	246,00	178,0	103,0	61,0
94,1	19,7	436,00	264,0	180,0	157,0
73,7	17,4	300,00	218,0	111,0	70,0
132,4	26,8	532,00	317,0	191,0	165,0
139,0	38,5	421,00	342,0	130,0	81,0
246,0	57,5	736,00	487,0	193,0	181,0

